

MOUNTY 100 V

101 HP



**The versatile tool carrier.
Good on slopes. Powerful. Comfortable.**

REFORM 

T E C H N O L O G Y A T I T S B E S T

Technical Specification Mouty 100 V

Engine: 4 cylinder 4 stroke diesel engine, VM-R754 IE3, 74 kW (101 hp) with turbocharger, intercooling and direct injection; water cooling, displacement 2970 cm³, torque 340 Nm at 1000–1600 rpm.

Gearbox: Hydrostatic drive with electronic control, with variable pump and variable motor, 3 speed ranges (with tyres 425/55 R17):

Range 1: 0–10 kph, Range 2: 0–20 kph, Range 3: 0–40 kph

Hydrostatic control optionally automotive or manual, electrically switchable Power limit control – constant pre-set engine speed by electro-hydraulic speed control, inching pedal, F/R shuttle operation.

Clutch: Multi disk clutch for PTO drive, electro-hydraulically switchable with automatic soft start.

Axles: Steering drive axles with final drive at front and rear, front axle oscillating.

Axle drive: four wheel drive, front-wheel drive preselectable connect and disconnect.

Differential locks: Preselectable, electrohydraulically operated differential locks front and rear, with switch status indicator lights on dashboard.

Steering: Hydrostatic "Load Sensing" steering, electrohydraulic steering switch during driving to four-wheel, front, rear and continuously adjustable crab steering; automatic synchronization of wheel position.

Front PTO: Power shift PTO 1000 rpm, ccw, electrohydraulically switchable with automatic soft start (direction of rotation: looking at PTO shaft end).

Rear PTO: Power shift PTO 540 and 750 rpm, cw, electrohydraulically switchable with automatic soft start (direction of rotation: looking at PTO shaft end).

Service brake: Hydraulic dual circuit 4 wheel multiple disc brake, in oil bath.

Parking brake: Spring-loaded parking brake acting on rear axle, electro-hydraulic release.

Engine hydraulics: Hydraulic pump 35 l/min, 195 bar, oil tank: 25 l, standard equipment **Variant B11:** Control valve s.a. for rear linkage; 1 control valve d.a. for front linkage, 2 control valves (d.a.f. and d.a.) with parallel lines front and rear, 1 tank return line each for front and rear, actuation by multi-function control lever.

Front linkage: Axle guided, cat. 2 with quick-release system using seating locators, electro-hydraulic weight compensation and vibration damping, electric external control, lifting force 1800 kg. Option: Integrated, hydraulic side shift with 450 mm adjustment range (+/- 225 mm).

Rear linkage: Lower link with hook end, cat. 2, electrical external control, adjustable lowering speed control, without drawbar, lifting force 2500 kg. Option: Vibration damping, d.a. linkage.

Electrical system: Full road lighting, battery 12 V / 100 Ah, alternator 140 A, front roof light, 1 rear working light.

Fuel tank: PE tank, capacity 110 l.

Cab: Vibration damped deluxe cab with heating and air conditioning, full glass doors and hinged rear window, tinted windows, noise absorbing interior trim, cab illumination, sunshade, coat hook, storage compartment, bottle holder, radio preparation in cab roof incl. 2 speakers and aerial, tool-less steering wheel adjustment, upright exhaust pipe and air intake, wiper, windscreen washer, 2 exterior mirrors, tool box; Option: Heated windscreen.

Seat design: Comfort seat with cloth cover, incl. arm rests and pelvic support, longitudinally, tilt and height adjustable; Option: Air cushioned seat with cloth cover.

Dashboard: Indicator light with symbols for differential locks, four wheel drive, hand brake, steering modes, fuel gauge, tachometer with integrated operating hours meter, daily hours counter, speedometer, clock, PTO speed front/rear, straight wheel alignment, coolant temperature display, cigarette lighter.

Wheel options: 425/55 R17 AG tyres (standard),

425/55 R17 All-Ground,

420/65 R20 AG tyres,

405/70 R20 AG tyres,

275/80 R20 AG tyres narrow track,

560/45 R22,5 AG tyres.

Auxiliary tyres with quick release: Front or rear:

7.50-18 AG with 425/55 R17, 9.5-24 AG with 405/70 R20 or 420/65 R20

Accessories: Mechanical or automatic trailer hitches, fixed or height-adjustable, (towing capacity 10.000 kg braked), rotating warning light, addtl. working light front or rear, stereo radio with CD or MC, hydraulic top link, hydraulic trailer brake.

Attachments: Front-end loader with single lever operation, rotary disc mower, side delivery belt rake, flail mower and extension arm boom flail mower, sickle mower, snow plough, snow blower, road brush, seed drill; further attachments on request.

Weights: Dead weight: 3625 kg with tyres 425/55 R17, perm. axle load F/R: 3800 kg, gross weight: 6000 kg.

Turning radius: 3,55 m (with 4-wheel steering)

Dimensions Mouty 100 V

with tyres 425/55 R17 / 405/70 R20

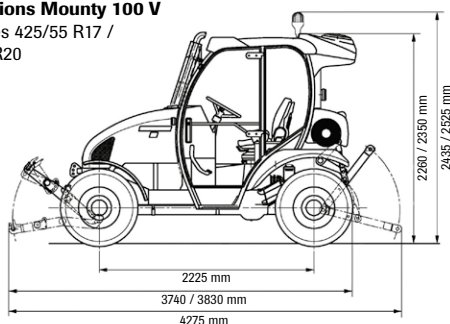

Your Reform partner

REFORM -WERKE

Bauer & Co Gesellschaft m.b.H.
Haidestrasse 40, A-4600 Wels
FN 139380 x, Wels Regional Court
Tel. 0043 / 7242 / 232 - 0
Fax 0043 / 7242 / 232 - 4
www.reform.at
E-mail: info@reform.at

AGROMONT AG

Postfach 142, Bösch 1
CH-6331 Hünenberg
Phone 0041 / 41 / 784 20 20
Fax 0041 / 41 / 784 20 22
www.agromont.ch
E-mail: info@agromont.ch

